

congatec Application Note



Applicable Products

conga-BM45, conga-BS45, conga-CS45, conga-BM57, conga-BS57, conga-BE57, conga-BM67 and conga-BS67, conga-BS77, conga-CCA, conga-BAF

Application Note Subject

Implementation Guide for HDMI and DisplayPort interface

Document Name

AN17_HDMI_DP_Implementation

Usage Designation

External

Application Note #17

Revision 1.7

Revision History

Revision	Date (dd.mm.yy)	Author	Changes
1.0	24.08.09	C. Hoch	Initial release
1.1	19.05.10	C. Hoch	Added description for DVI implementation, added BM57, BS57 and BE57.
1.2	23.09.10	C. Hoch	Added schematics for DVI, HDMI and DP
1.3	04.10.10	C. Hoch	Updated schematics. Added Note about HPDEN pin of Chronitel CH7318.
1.4	28.12.10	C. Hoch	Updated sections HDMI and DP Audio, DisplayPort D and SDVO Port C. Corrected minor mistakes.
1.5	16.02.11	C. Hoch	Updated schematics HDMI, DVI and DP. Corrected minor mistakes.
1.6	03/27/12	C. Hoch C. Riesinger	Corrected minor mistakes. Added conga-Bx67 (BM67 and BS67)
1.7	02/07/13	C. Riesinger	Added conga-CCA, conga-BAF and conga-BS77

Preface

This application note provides information about implementing a HDMI or DisplayPort interface on COM Express™ carrier boards.

Disclaimer

The information contained within this Application Note, including but not limited to any product specification, is subject to change without notice. congatec AG provides no warranty with regard to this Application Note or any other information contained herein and hereby expressly disclaims any implied warranties of merchantability or fitness for any particular purpose with regard to any of the foregoing. congatec AG assumes no liability for any damages incurred directly or indirectly from any technical or typographical errors or omissions contained herein or for discrepancies between the product and the Application Note. In no event shall congatec AG be liable for any incidental, consequential, special, or exemplary damages, whether based on tort, contract or otherwise, arising out of or in connection with this Application Note or any other information contained herein or the use thereof.

Intended Audience

This Application Note is intended for technically qualified personnel. It is not intended for general audiences.

Symbols

The following symbols may be used in this Application Note:



Warning

Warnings indicate conditions that, if not observed, can cause personal injury.



Caution

Cautions warn the user about how to prevent damage to hardware or loss of data.



Note

Notes call attention to important information that should be observed.

Electrostatic Sensitive Device



All congatec AG products are electrostatic sensitive devices and are packaged accordingly. Do not open or handle a congatec AG product except at a electrostatic-free workstation. Additionally, do not ship or store congatec AG products near strong electrostatic, electromagnetic, magnetic, or radioactive fields unless the device is contained within its original manufacturer's packaging. Be aware that failure to comply with these guidelines will void the congatec AG Limited Warranty.

Terminology

Some of the following terms may be used throughout this document.

Term	Description
T.B.D.	To be determined
HDMI	High Definiton Multimedia Interface
SDVO	Serial Digital Video Out
DVI	Digital Video Interface
PEG	PCI Express Graphics
DP	DisplayPort Interface
conga-Bx57	conga-BM57, conga-BS57, conga-BE57
conga-Bx67	conga-BM67, conga-BS67

Copyright Notice

Copyright © 2009, congatec AG. All rights reserved. All text, pictures and graphics are protected by copyrights. No copying is permitted without written permission from congatec AG. congatec AG has made every attempt to ensure that the information in this document is accurate yet the information contained within is supplied “as-is”.

Trademarks

Intel and Pentium are registered trademarks of Intel Corporation. COM Express™ is a registered trademark of PCI Industrial Computer Manufacturers Group. PCI Express is a registered trademark of Peripheral Component Interconnect Special Interest Group (PCI-SIG). I²C is a registered trademark of Philips Corporation. conga, congatec and XTX are registered trademark of congatec AG. All product names and logos are property of their owners.

Contents

1 Introduction.....	6
2 Pinout on congatec COM Express™ Modules.....	7
3 High Definition Multimedia Interface (HDMI).....	9
3.1 HDMI Implementation.....	9
3.1.1 HDMI Example Schematics.....	9
3.1.2 Enable HDMI Support.....	11
3.1.3 HDMI Connector Pinout.....	13
3.1.4 HDMI Hot-plug Detection.....	14
3.2 HDMI Audio.....	14
3.3 HDCP.....	15
4 Digital Video Interface (DVI).....	16
4.1 DVI Implementation.....	16
4.1.1 DVI Example Schematics.....	16
4.1.2 Enable DVI Support.....	18
4.1.3 DVI Pinout.....	18
4.1.4 DVI Hot-plug Detection.....	19
5 DisplayPort (DP).....	20
5.1 DisplayPort Implementation.....	20
5.1.1 DP Example Schematics.....	20
5.1.2 DisplayPort Hot-plug Detection.....	22
5.1.3 Enable DisplayPort Support.....	22
5.1.4 DisplayPort Connector Pinout.....	24
5.1.5 DisplayPort Hot-plug Detection.....	24
5.2 DisplayPort Audio.....	24
6 Layout Design Constraints.....	25

1 Introduction

The latest chipsets used on congatec COM Express™ modules not only provide LVDS and SDVO graphics interfaces but also the new generation of interfaces such as HDMI and DisplayPort.

High-Definition Multimedia Interface (HDMI) is a licensable compact audio/video connector interface for transmitting uncompressed digital streams. HDMI encodes the video data and audio data into TMDS for digital transmission and is fully backward-compatible with the single-link Digital Visual Interface (DVI) carrying digital video. Additionally, HDMI adds the ability to send up to 8 separate channels of uncompressed digital audio and auxiliary control data during the horizontal and vertical blanking intervals of the TDMS video stream.

DisplayPort is an open industry standard digital display interface that is under development within the Video Electronics Standards Association (VESA). The DisplayPort specification defines a scalable digital display interface with optional audio and content protection capability. It defines a license-free, royalty-free, state-of-the-art digital audio/video interconnect intended to be used primarily between a computer and its display monitor.

2 Pinout on congatec COM Express™ Modules

Table 1 Shared signals PCI Express, SDVO, HDMI and DisplayPort on congatec Type 2 COM Express™ modules

COM Express™		x16 PCI Express (PEG)		Corresponds with SDVO signal		Corresponds with HDMI signal		Corresponds with DisplayPort signal	
Pin	Name	Pin	Name	Pin Name	Description	Pin Name	Description	Pin Name	Description
D52	PEG_TX[0]+	B14	HSOp(0)	SDVOB_RED+	Digital Video B red output differential pair	TMDS_B_DATA2+	HDMI Port B Data2 output differential pair.	DPB_LANE0+	DisplayPort B Lane0 output differential pair.
D53	PEG_TX[0]-	B15	HSOn(0)	SDVOB_REDSerial		TMDS_B_DATA2-		DPB_LANE0-	
D55	PEG_TX[1]+	B19	HSOp(1)	SDVOB_GRN+	Digital Video B green output differential pair	TMDS_B_DATA1+	HDMI Port B Data1 output differential pair.	DPB_LANE1+	DisplayPort B Lane1 output differential pair.
D56	PEG_TX[1]-	B20	HSOn(1)	SDVOB_GRNSerial		TMDS_B_DATA1-		DPB_LANE1-	
D58	PEG_TX[2]+	B23	HSOp(2)	SDVOB_BLU+	Digital Video B blue output differential pair	TMDS_B_DATA0+	HDMI Port B Data0 output differential pair.	DPB_LANE2+	DisplayPort B Lane2 output differential pair.
D59	PEG_TX[2]-	B24	HSOn(2)	SDVOB_BLUSerial		TMDS_B_DATA0-		DPB_LANE2-	
D61	PEG_TX[3]+	B27	HSOp(3)	SDVOB_CK+	Digital Video B clock output differential pair	TMDS_B_CLK +	HDMI Port B Clock output differential pair.	DPB_LANE3+	DisplayPort B Lane3 output differential pair.
D62	PEG_TX[3]-	B28	HSOn(3)	SDVOB_CKSerial		TMDS_B_CLK -		DPB_LANE3-	
D65	PEG_TX[4]+	B33	HSOp(4)	SDVOC_RED+	Digital Video C red output differential pair	TMDS_C_DATA2+	HDMI Port C Data2 output differential pair.	DPC_LANE0+	DisplayPort C Lane0 output differential pair.
D66	PEG_TX[4]-	B34	HSOn(4)	SDVOC_REDSerial		TMDS_C_DATA2-		DPC_LANE0-	
D68	PEG_TX[5]+	B37	HSOp(5)	SDVOC_GRN+	Digital Video C green output differential pair	TMDS_C_DATA1+	HDMI Port C Data1 output differential pair.	DPC_LANE1+	DisplayPort C Lane1 output differential pair.
D69	PEG_TX[5]-	B38	HSOn(5)	SDVOC_GRNSerial		TMDS_C_DATA1-		DPC_LANE1-	
D71	PEG_TX[6]+	B41	HSOp(6)	SDVOC_BLU+	Digital Video C blue output differential pair	TMDS_C_DATA0+	HDMI Port C Data0 output differential pair.	DPC_LANE2+	DisplayPort C Lane2 output differential pair.
D72	PEG_TX[6]-	B42	HSOn(6)	SDVOC_BLUSerial		TMDS_C_DATA0-		DPC_LANE2-	
D74	PEG_TX[7]+	B45	HSOp(7)	SDVOC_CK+	Digital Video C clock output differential pair	TMDS_C_CLK +	HDMI Port C Clock output differential pair.	DPC_LANE3+	DisplayPort C Lane3 output differential pair.
D75	PEG_TX[7]-	B46	HSOn(7)	SDVOC_CKSerial		TMDS_C_CLK -		DPC_LANE3-	
D78	PEG_TX[8]+	B50	HSOp(8)	-	-	-	-	DPD_LANE0+	DisplayPort D Lane0 output differential pair.
D79	PEG_TX[8]-	B51	HSOn(8)	-	-	-	-	DPD_LANE0-	
D81	PEG_TX[9]+	B54	HSOp(9)	-	-	-	-	DPD_LANE1+	DisplayPort D Lane1 output differential pair.
D82	PEG_TX[9]-	B55	HSOn(9)	-	-	-	-	DPD_LANE1-	
D85	PEG_TX[10]+	B58	HSOp(10)	-	-	-	-	DPD_LANE2+	DisplayPort D Lane2 output differential pair.
D86	PEG_TX[10]-	B59	HSOn(10)	-	-	-	-	DPD_LANE2-	
D88	PEG_TX[11]+	B62	HSOp(11)	-	-	-	-	DPD_LANE3+	DisplayPort D Lane3 output differential pair.
D89	PEG_TX[11]-	B63	HSOn(11)	-	-	-	-	DPD_LANE3-	
C52	PEG_RX[0]+	A16	HSIp(0)	SDVO_TVCLKIN+	Digital Video TVOUT synchronization clock input differential pair	-	-	-	-
C53	PEG_RX[0]-	A17	HSIn(0)	SDVO_TVCLKINSerial		-	-	-	-
C55	PEG_RX[1]+	A21	HSIp(1)	SDVOB_INT+	Digital Video B interrupt input differential pair	-	-	-	-
C56	PEG_RX[1]-	A22	HSIn(1)	SDVOB_INTSerial		-	-	-	-
C58	PEG_RX[2]+	A25	HSIp(2)	SDVO_FLDSTALL+	Digital Video Field Stall input differential pair	-	-	DPB_AUX+	DisplayPort B Aux input differential pair.
C59	PEG_RX[2]-	A26	HSIn(2)	SDVO_FLDSTALLSerial		-	-	DPB_AUX-	

Application Note

COM Express™		x16 PCI Express		Corresponds with SDVO signal		Corresponds with HDMI signal		Corresponds with DisplayPort signal	
Pin	Name	Pin	Name	Pin Name	Description	Pin Name	Description	Pin Name	Description
C61	PEG_RX[3]+	A29	HSIp(3)	-		TMDS_B_HPD	HDMI Port B Hot-plug detect.	DPB_HPD	DisplayPort B Hot-plug detect.
C68	PEG_RX[5]+	A39	HSIp(5)	SDVOC_INT+	Digital Video C interrupt input	-		-	
C69	PEG_RX[5]-	A40	HSIn(5)	SDVOC_INT-	differential pair	-		-	
C71	PEG_RX[6]+	A43	HSIp(6)	-		-		DPC_AUX+	DisplayPort C Aux input
C72	PEG_RX[6]-	A44	HSIn(6)	-		-		DPC_AUX-	differential pair.
C74	PEG_RX[7]+	A47	HSIp(7)	-		TMDS_C_HPD	HDMI Port C Hot-plug detect.	DPC_HPD	DisplayPort C Hot-plug detect.
C85	PEG_RX[10]+	A60	HSIp(10)	-		-		DPD_AUX+	DisplayPort D Aux input
C86	PEG_RX[10]-	A61	HSIn(10)	-		-		DPD_AUX-	differential pair.
C88	PEG_RX[11]+	A64	HSIp(11)	-		-		DPD_HPD#	DisplayPort D Hot-plug detect.
D73	SDVO_CLK	B17	PRSNT#2	SDVO_I2C_CK	SDVO I ² C clock line to set up SDVO peripherals	DDPB_CTRLCLK	HDMI port B Control Clock	-	
C73	SDVO_DATA	B31	PRSNT#2	SDVO_I2C_DAT	SDVO I ² C data line to set up SDVO peripherals	DDPB_CTRLDATA	HDMI port B Control Data DDPB_CTRLDATA is a boot strap signal (see note below)	DDPB_CTRLDATA	DDPB_CTRLDATA is a boot strap signal (see note below)
D63	RSVD	A1	PRSNT#1	-		DDPC_CTRLCLK	HDMI port C Control Clock	-	
D64	RSVD	B81	PRSNT#2	-		DDPC_CTRLDATA	HDMI port C Control Data DDPC_CTRLDATA is a boot strap signal (see note below)	DDPC_CTRLDATA	DDPC_CTRLDATA is a boot strap signal (see note below)
D83	RSVD	-		-		-		DDPD_CTRLDATA	DDPC_CTRLDATA is a boot strap signal (see note below)

These signals are not supported on conga-Bx57, conga-Bx67 and conga-BS77

These signals are not supported on conga-Bx45 and conga-CS45

conga-CCA offers HDMI and DisplayPort support on Port B only

conga-BAF offers HDMI and DisplayPort support on Port B and C

Note

This signal has to be pulled up to 3.3V using a 2.2kOhm resistor to enable the respective graphics port. This does not apply to the conga-BAF module. Refer to section 3.1.2 and 5.1.3 of this application note for more information.

3 High Definition Multimedia Interface (HDMI)

The congatec COM Express™ modules offer two single-link HDMI interfaces (Port B and Port C) with a pixel clock rate of up to 165MHz. The appropriate TDMS receive and transmit differential signal pair, as well as additional control signals, can be found on the COM Express™ module connector. This interface is shared with the PEG, SDVO and DisplayPort signals (see Table 1).

The HDMI port provides a two-wire point-to-point communication path between the HDMI device and the Intel GMCH. The HDMI control clock and data (DDPx_CTRLDATA and DDPx_CTRLCLK) provide similar functionality to I²C. However, unlike I²C this interface is intended to be point-to-point and will require the SDVO device to act as a switch and direct traffic from the SDVO control bus to the appropriate receiver. Additionally, this control bus will be able to run at faster speeds (up to 1MHz) than a traditional I²C interface.

3.1 HDMI Implementation

The HDMI interface on congatec COM Express™ modules is provided by the chipset's integrated graphics engine. This HDMI interface is multiplexed with the PCI Express Graphics (PEG), SDVO and DisplayPort interface. Since all of these interfaces are low-swing AC coupled differential inputs, high speed HDMI level shifters are required to translate the signals to the HDMI compliant open-drain current steering Rx terminated differential output.

HDMI level shifters are available from different manufacturers such as Chrontel CH7318 (<http://www.chrontel.com>), Parade Technologies PS101QFN48G (<http://www.paradetech.com>) or Pericom Semiconductor PI3VDV411LSZDE (<http://www.pericom.com>).

Note

In order for the HDMI interface to be compliant with the HDMI Specification, level shifters must be implemented on the carrier board for the HDMI signals.

3.1.1 HDMI Example Schematics

The following schematic example is based on the Chrontel CH7318C level shifter.

Application Note AN17

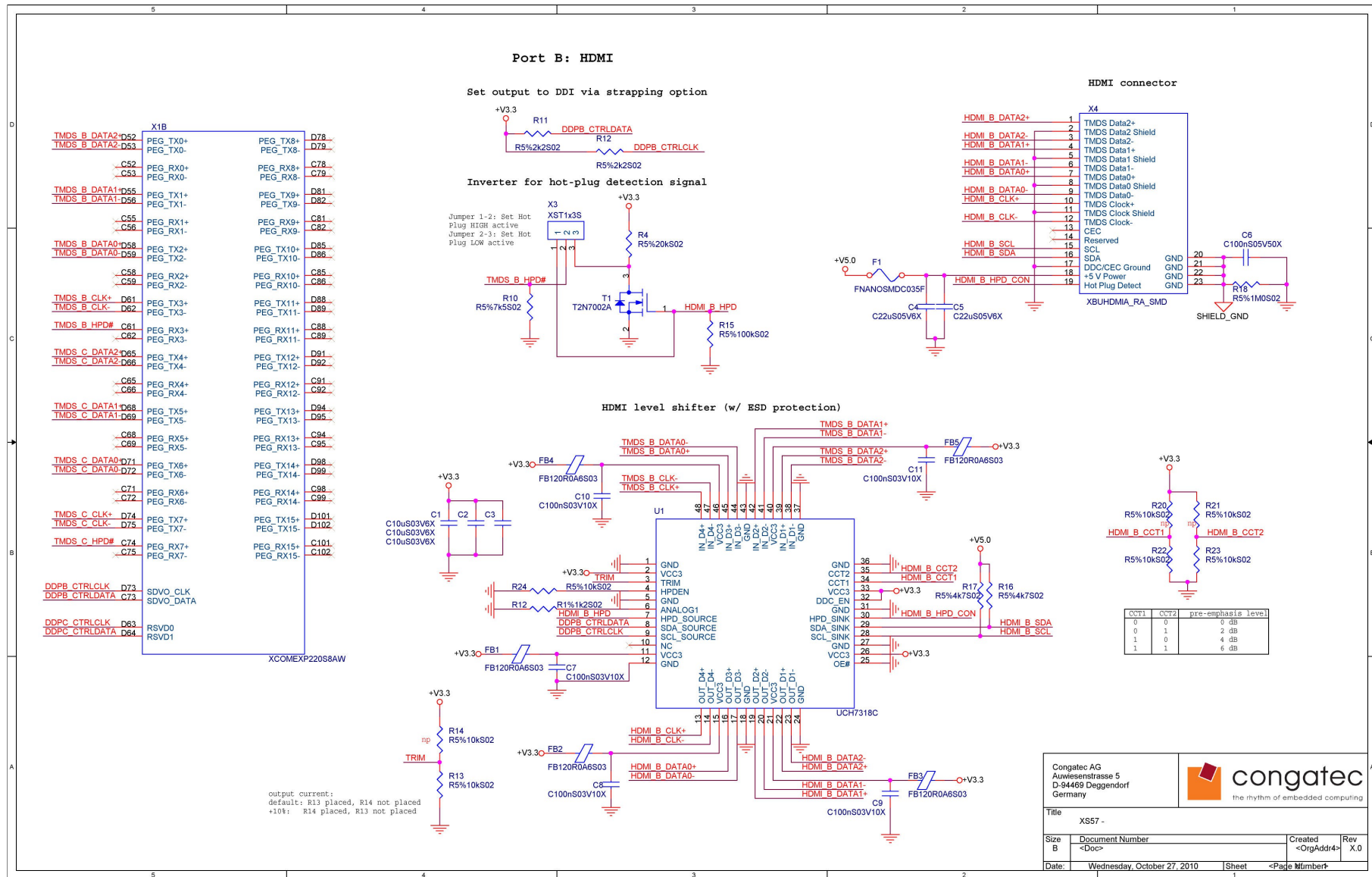

3.1.2 Enable HDMI Support

To enable HDMI support, the control data line of the respective HDMI Port B or Port C (DDPx_CTRLDATA - see Table 1) must be pulled to +3.3V by a 2.2kOhm resistor (not applicable to conga-BAF).

Additionally, a BIOS setup configuration is necessary to enable the HDMI interface. The setup nodes shown below (located in the Graphics Configuration sub-menu within the congatec BIOS Setup Program) must be set to 'HDMI Port' for the respective port (Port B or C).

Table 2 BIOS Graphics Configuration Submenu of conga-BM45, conga-BS45 and conga-CS45

Feature	Options	Description
SDVO Port B Configuration	Disabled HDMI Port Display Port SDVO DVI (default setting)	Select the SDVO device connected to this SDVO port or configure the port as HDMI or Display Port.
SDVO Port C Configuration	Disabled HDMI Port Display Port SDVO DVI (default setting)	Select the SDVO device connected to this SDVO port or configure the port as HDMI or Display Port.

conga-Bx57, conga-Bx67 and conga-BS77

Feature	Options	Description
Display Port B Interface	Disabled (default setting) SDVO Display Port HDMI/DVI	Select the interface the physical display port should offer.
Display Port C Interface	Disabled (default setting) Display Port HDMI/DVI	Select the interface the physical display port should offer.
Display Port D Interface	Disabled (default setting) Display Port HDMI/DVI	Select the interface the physical display port should offer.

Application Note AN17

conga-CCA

Feature	Options	Description
DDI Port B	Disabled Display Port HDMI/DVI	Select the Digital Display Interface offered by the Graphic Pipe B.

conga-BAF

Feature	Options	Description
Display Channel 0 Output	Display Port C HDMI C LVDS Disabled	Define output mode and connection of the integrated display channel 0. This port can also be used for LVDS support provided by an on-board eDP to LVDS converter chip.
Display Channel 1 Output	Display Port B HDMI B Disabled	Define output mode and connection of the integrated display channel1.

3.1.3 HDMI Connector Pinout

Figure 3-1 HDMI Connector (Type A - male, front view)

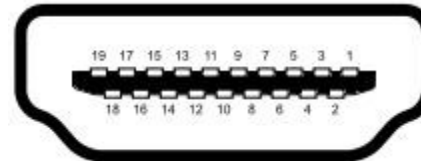

Table 3 Pinout HDMI Connector

Pin#	Signal	Description	Pin#	Signal	Description
1	TMDS Data 2+	HDMI Lane 2 (positive)	2	TMDS Data 2 Shield	Shield of Data 2 pair
3	TMDS Data 2-	HDMI Lane 2 (negative)	4	TMDS Data 1+	HDMI Lane 1 (positive)
5	TMDS Data 1 Shield	Shield of Data 1 pair	6	TMDS Data 1-	HDMI Lane 1 (negative)
7	TMDS Data 0+	HDMI Lane 0 (positive)	8	TMDS Data0 Shield	Shield of Data 0 pair
9	TMDS Data 0-	HDMI Lane 0 (negative)	10	TMDS Clock-	HDMI Clock (positive)
11	TMDS Clock Shield	Shield of Clock pair	12	TMDS Clock-	HDMI Clock (negative)
13	CEC	Consumer Electronics Control Interface	14	Reserved	N.C.
15	DDC Clock	DDC based control signal (clock)	16	DDC Data	DDC based control signal (data)
17	GND	Ground	18	+5V	+5V Power Supply
19	HPD	Hot plug detect			

3.1.4 HDMI Hot-plug Detection

Due to the different chipsets used on the congatec COM Express modules, the hot-plug detection signal for the HDMI and the DisplayPort reacts differently to signal levels. The HDMI and the DisplayPort hot-plug detection is activated with low-active signal on the conga-BM45, conga-BS45, conga-CS45 and conga-BAF modules while on the conga-Bx57, conga-Bx67, conga-BS77 and conga-CCA modules with a high-active signal.

In order to ensure compatible carrier board designs among these modules and/or future modules, congatec recommends the design of an optional inverter as shown in the schematics example in section 3.1.1 .



Instead of the inverter for the hot-plug detection signal (HDMI_B_HPD) shown in the schematics in section 3.1.1 , the 'HPDEN' signal input of the Chrontel CH7318 controller can be used to generate the adequate polarity of the hot-plug detection signal required by congatec modules. Keep in mind that when the signal inversion is performed by using the 'HPDEN' pin, the 'HDMI_B_HPD' signal level must be additionally adapted according to the application notes provided by Chrontel (<http://www.chrontel.com>).

3.2 HDMI Audio

congatec conga-BM45, conga-BS45 and conga-CS45 COM Express™ modules do not support HDMI audio. The conga-Bx57, conga-Bx67, conga-BS77 and conga-CCA support HDMI audio. HDMI audio has to be enabled in the BIOS setup (see Table 4) and additionally, the module's operating system graphics driver has to be installed (or reinstalled).

Table 4 BIOS Chipset Configuration Submenu conga-Bx57, Bx67 and BS77

Feature	Options	Description
HDA Controller internal HDMI Codec	Enabled Disabled (default setting)	Enable or disable the internal HDMI codec for the HDA Controller.

3.3 HDCP

HDMI can use HDCP (High-bandwidth Digital Content Protection) to encrypt the signal if this is required by the source device. Digital Rights Management (DRM) requires HDCP on the HDMI interface when playing back encrypted DVD Video, DVD Audio, HD DVD, and Blue-Ray Disc. HDCP controls the authentication and switching/distribution of the HDMI signal so that it can only be routed to the corresponding device.

HDCP is not supported by default on the the congatec COM Express™ modules. For more information about HDCP support on congatec modules, contact congatec technical support.

4 Digital Video Interface (DVI)

The video signals used on the DVI interface are electrically compatible with HDMI video signals. No signal conversion is required and no loss in video quality occurs when the HDMI signal of the congatec COM Express™ module is used to implement a DVI interface.



Note

Some DVI devices may not support HDCP (see section 3.3 of this document). Ensure that a HDCP-enabled signal source is not used in this case.

4.1 DVI Implementation

Refer to the description in the section 3.1 of this document.



Note

As described in section 3.1 for HDMI implementation, the DVI signals also require level shifters on the carrier board to be compliant with the DVI Specification.

For compatibility with congatec COM Express™ modules that do not support HDMI, the DVI interface can be implemented by using a SDVO-to-DVI transmitter. This does not apply to the conga-CCA and conga-BAF COM Express™ modules because they do not support SDVO. For more details on this solution, consult the congatec “Design Guide for SDVO” on the congatec website at (<http://www.congatec.com>).

4.1.1 DVI Example Schematics

The following schematic example is based on the Chrontel CH7318C level shifter.

Application Note AN17

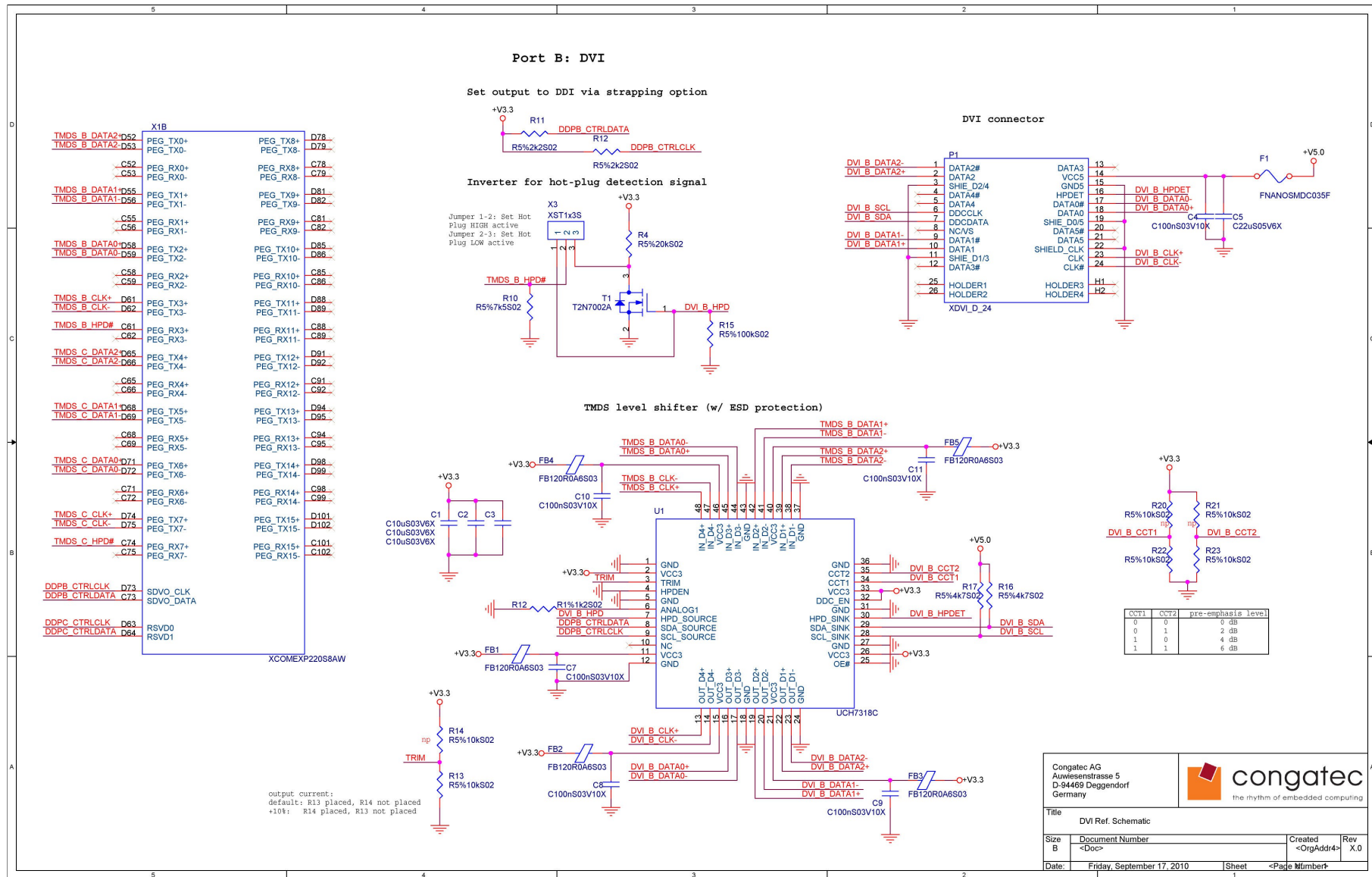

4.1.2 Enable DVI Support

Refer to the description in section 3.1.2 of this document.

Note

The same configuration as described in section 3.1.2 should be used. Do not use the BIOS setting 'SDVO DVI'. This setting must be applied when an SDVO to DVI codec is used on the carrier board. For details about SDVO, refer to the 'Design Guide for SDVO' on the congatec website.

4.1.3 DVI Pinout

Figure 4-1 DisplayPort Connector (female, front view)

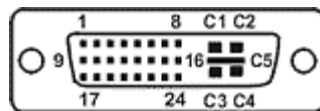

Table 5 Pinout DVI-I Connector

Pin#	Signal	Description	Pin#	Signal	Description
1	TMDS Data 2-	DVI Lane 2 (negative)	2	TMDS Data 2+	DVI Lane 2 (positive)
3	TMDS Data 2/4 SHIELD	Shield of Data pair 2 and 4	4	TMDS Data 4-	DVI Lane 4 (negative)
5	TMDS Data 4+	DVI Lane 4 (positive)	6	DDC Clock	DDC based control signal (clock)
7	DDC Data	DDC based control signal (data)	8	ANALOG VERT SYNC	Analog Vertical Synchronization
9	TMDS Data 1-	DVI Lane 1 (negative)	10	TMDS DATA 1+	DVI Lane 1 (negative) HDMI Clock (positive)
11	TMDS DATA 1/3 SHIELD	Shield of Data pair 1 and 3	12	TMDS DATA 3-	DVI Lane 3 (negative)
13	TMDS DATA 3+	DVI Lane 3 (positive)	14	+5V	+5V Power Supply
15	GND	Ground	16	HPD	Hot plug detect
17	TMDS Data 0-	DVI Lane 0 (negative)	18	TMDS Data 0+	DVI Lane 0 (positive)
19	TMDS Data 0/5 SHIELD	Shield of Data pair 0 and 5	20	TMDS Data 5-	DVI Lane 5 (negative)
21	TMDS Data 5+	DVI Lane 5 (positive)	22	TMDS Clock Shield	Shield of Clock pair

Pin#	Signal	Description	Pin#	Signal	Description
23	TMDS Clock+	DVI Clock (positive)	24	TMDS Clock -	DVI Clock (negative)
C1	ANALOG RED	Analog Red	C2	ANALOG GREEN	Analog Green
C3	ANALOG BLUE	Analog Blue	C4	ANALOG HORZ SYNC	Analog Horizontal Synchronization
C5	ANALOG GND	Analog ground (Return for R, G and B signals)			

Different kinds of video signals can be implemented depending on the DVI connector pinout. The DVI-D connector implements only the digital video signals while the DVI-A connector implements only the analog video signals (marked in light grey in the table above). When a DVI connector incorporates both digital and analog video signals it is referred to as DVI-I (integrated).

4.1.4 DVI Hot-plug Detection

Refer to section 3.1.4 of this Application Note.

5 DisplayPort (DP)

The congatec conga-CCA COM Express™ module supports only one DisplayPort interface (Port B). Two DisplayPort interfaces (Port B and Port C) are supported on the conga-BM45, conga-BS45, conga-CS45 and conga-BAF while the conga-Bx57, conga-Bx67 and BS77 modules support three DisplayPort interfaces (Port B, C and D)

The appropriate TDMS receive and transmit differential signal pair, as well as additional control signals, can be found on the connector of the COM Express™ module. This interface might be shared with the PEG, SDVO and HDMI/DVI signals (see Table 1).



Note

The boot strap signal used to enable the DisplayPort D (DDPD_CTRLDATA) is not part of the COM Express™ standard. congatec used a reserved (RSVD) pin for this signal. The signal is also not available at the PCI Express Graphics (PEG) connector. This means that the boot strapping must be implemented on the customers COM Express™ carrier board. This does not apply to the conga-BAF module.

5.1 DisplayPort Implementation

The DisplayPort interface supports 1, 2, or 4 data pairs that carry the video signal, clock and optional audio signals. The video signal of the DisplayPort interface is not compatible with DVI or HDMI but a DisplayPort connector can pass these signals through. While HDMI/DVI require separate clock signals, DisplayPort embeds the clock in the data signal. Unlike the separate HDMI/DVI and LVDS standards, DisplayPort supports both external (monitor) or internal (LCD panel) display connections.

5.1.1 DP Example Schematics

See the following page.

Application Note AN17

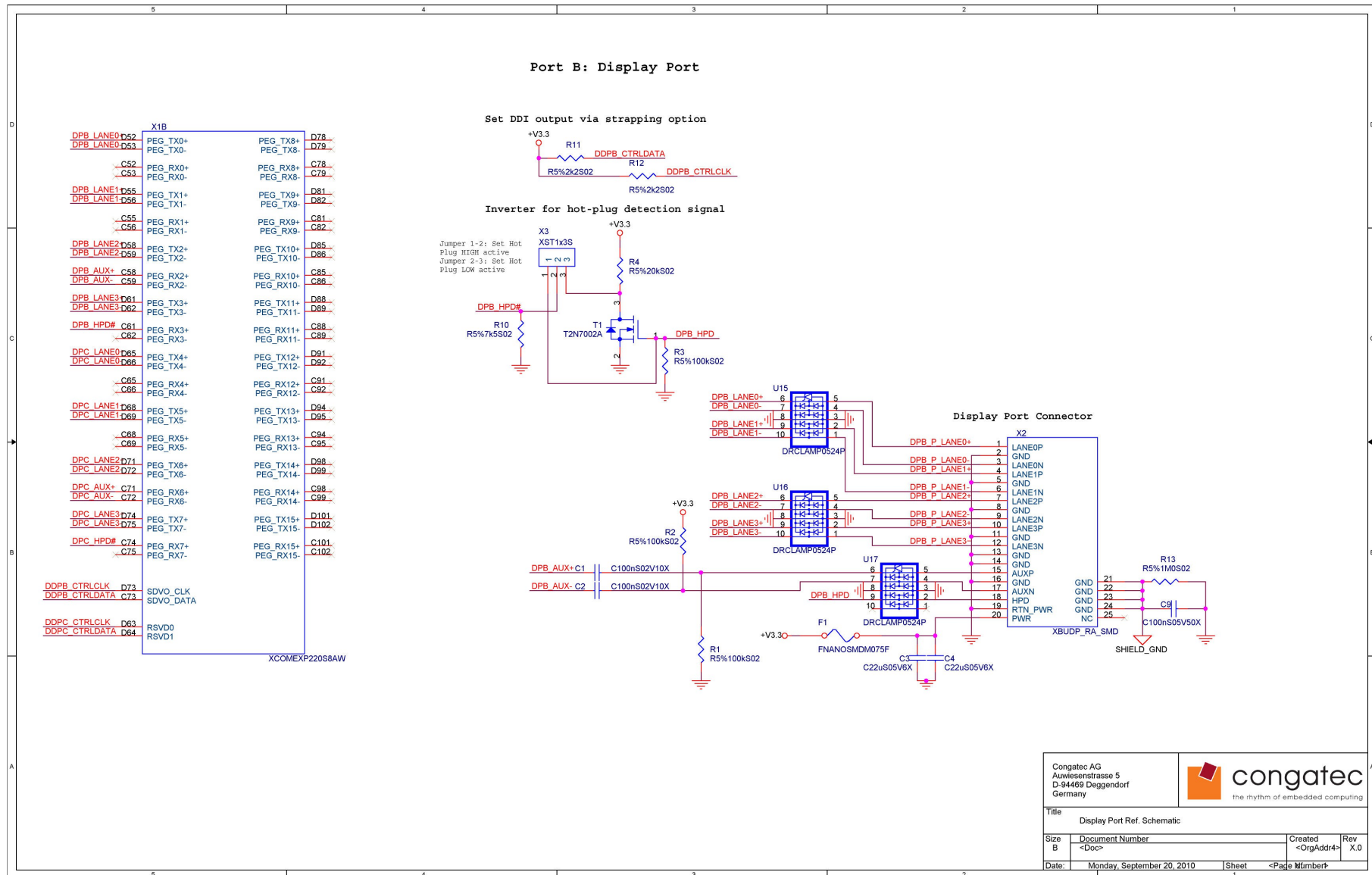

Congatec AG Auwiesenstrasse 5 D-94469 Deggendorf Germany		 congatec the rhythm of embedded computing	
Title: Display Port Ref. Schematic			
Size B	Document Number	Created	Rev
	<Doc>	<OrgAddr4>	X.0
Date:	Monday, September 20, 2010	Sheet	<Page N/number>

5.1.2 DisplayPort Hot-plug Detection

Refer to the description in the section 3.1.4 of this document

5.1.3 Enable DisplayPort Support

To enable the DisplayPort support, the control data lines of the respective Graphics Port B, Port C or Port D (DDPx_CTRLDATA - see Table 1) must be pulled to +3.3V by a 2.2kOhm resistor.

Additionally, a BIOS setup configuration is necessary to enable the DisplayPort interface. The setup nodes shown below (located in the Graphics Configuration Submenu within the congatec BIOS Setup Program) have to be set to 'DisplayPort Port' for the respective port (Port B or C).

Table 6 BIOS Graphics Configuration Submenu conga-BM45, conga-BS45 and conga-CS45:

Feature	Options	Description
SDVO Port B Configuration	Disabled HDMI Port Display Port SDVO DVI (default setting)	Select the SDVO device connected to this SDVO port or configure the port as HDMI or Display Port.
SDVO Port C Configuration	Disabled HDMI Port Display Port SDVO DVI (default setting)	Select the SDVO device connected to this SDVO port or configure the port as HDMI or Display Port.

conga-Bx57, conga-Bx67 and conga-BS77

Feature	Options	Description
Display Port B Interface	Disabled (default setting) SDVO Display Port HDMI/DVI	Select the interface the physical display port should offer.
Display Port C Interface	Disabled (default setting) Display Port HDMI/DVI	Select the interface the physical display port should offer.
Display Port D Interface	Disabled (default setting) Display Port HDMI/DVI	Select the interface the physical display port should offer.

conga-CCA

Feature	Options	Description
DDI Port B	Disabled Display Port HDMI/DVI	Select the Digital Display Interface offered by the Graphic Pipe B.

conga-BAF

Feature	Options	Description
Display Channel 0 Output	Display Port C HDMI C LVDS Disabled	Define output mode and connection of the integrated display channel 0. This port can also be used for LVDS support provided by an on-board eDP to LVDS converter chip.
Display Channel 1 Output	Display Port B HDMI B Disabled	Define output mode and connection of the integrated display channel1.

5.1.4 DisplayPort Connector Pinout

Figure 5-1 DisplayPort Connector (male, front view)

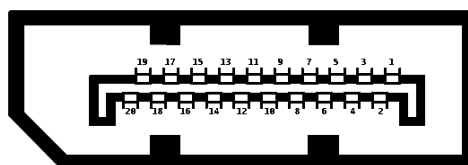

Table 7 Pinout DisplayPort Connector

Pin#	Signal	Description	Pin#	Signal	Description
1	DP_LANE0+	DisplayPort Lane 0 (positive)	2	GND	Ground
3	DP_LANE0-	DisplayPort Lane 0 (negative)	4	DP_LANE1+	DisplayPort Lane 1 (positive)
5	GND	Ground	6	DP_LANE1-	DisplayPort Lane 1 (negative)
7	DP_LANE2+	DisplayPort Lane 2 (positive)	8	GND	Ground
9	DP_LANE2-	DisplayPort Lane 2 (negative)	10	DP_LANE3+	DisplayPort Lane 3 (positive)
11	GND	Ground	12	DP_LANE3-	DisplayPort Lane 3 (negative)
13	CONFIG1	Configuration Pin 1 (connected to Ground)	14	CONFIG2	Configuration Pin 2 (connected to Ground)
15	DP_AUX+	Auxiliary Channel (positive)	16	GND	Ground
17	DP_AUX-	Auxiliary Channel (negative)	18	DP_HPD#	Hot Plug Detect
19	RETURN	Return For Power	20	DP_PWR	Power For Connector

5.1.5 DisplayPort Hot-plug Detection

Refer to section 3.1.4 of this Application Note.

5.2 DisplayPort Audio

Refer to section 3.2 of this Application Note.

6 Layout Design Constraints

For HDMI, DVI or DisplayPort hardware design, congatec highly recommends complete adherence to the PCI Express Trace Routing Guidelines described in the PICMG COM Express™ (COM.0) Design Guide (<http://www.picmg.org/>).